

9" SQUARE RETROFIT MOFLOW™ SUCTION OUTLET COVER WITH SCREW AND BUSHING KIT



VGB CERTIFIED SPECIFICATIONS

Floor Flow Rating

258 GPM at 2.3 fps

Wall Flow Rating

274 GPM at 2.5 fps

Sump Depth

3" minimum

Open Area

35.8 in²

FEATURES

All components meet or exceed ANSI/APSP 16-2011 and NSF/ANSI 50-2009a national standards and ASTM G154 UV testing exposure

Easily and safely retrofits to most brands' 1" deep existing frames. Does not include mud frame

#316 stainless steel screws

Manufactured from superior UV-resistant engineered polymers

Trademarked VGB compliance button easily identifies VGB 2008 compliant cover from on deck and underwater

Online product support including downloadable certificate of conformity, third-party certificate, installation instructions and more

Replace drain cover every five years from the date of installation

6 per case

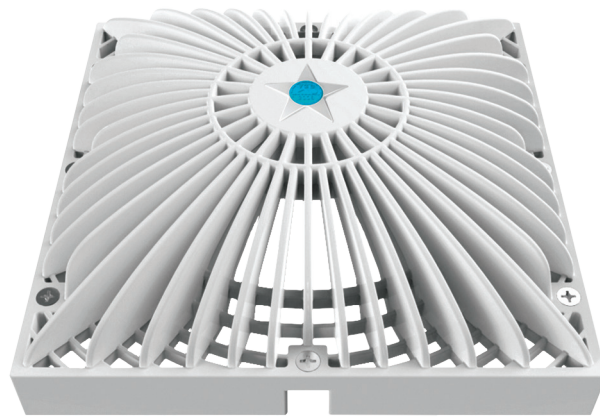

Part # R9MFxxx

Fits: AquaStar "R" 9" models, Hayward, Waterway, American (Pentair #2 selling), PacFab with 1" deep existing frames and four screw hole pattern

STANDARD COLORS

- R9MF101 – White
- R9MF102 – Black
- R9MF103 – Light Gray
- R9MF104 – Blue
- R9MF105 – Dark Gray
- R9MF108 – Tan

Replaces RFS9xxx

VGB 2008 Compliant

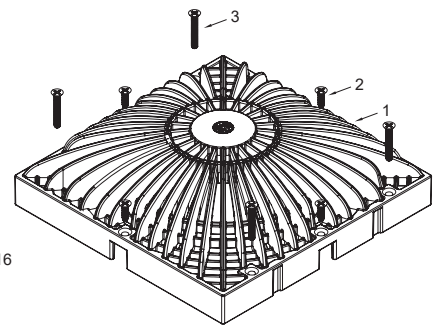
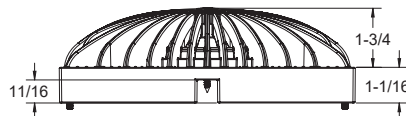
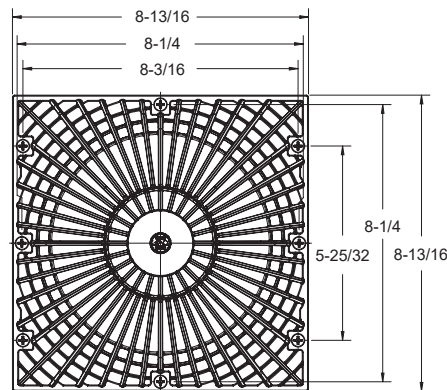

1. 9" Square Retrofit MoFlow Suction Outlet Cover
2. 10 x 1" Flat Head Phillips, 316 SS, Qty 4
3. 10-24 x 1-1/4" Flat Head Phillips, 316 SS, Qty 4